

RUDDER:	AILERON/RUDDER	ELEVATOR:
NORMAL ±27	NORMAL ±15	NORMAL ±10
START ±27	START ±27	START ±16 -1
SPEED ±27	SPEED ±0	SPEED ±16
LANDING ±27	LANDING ±27	LANDING ±16

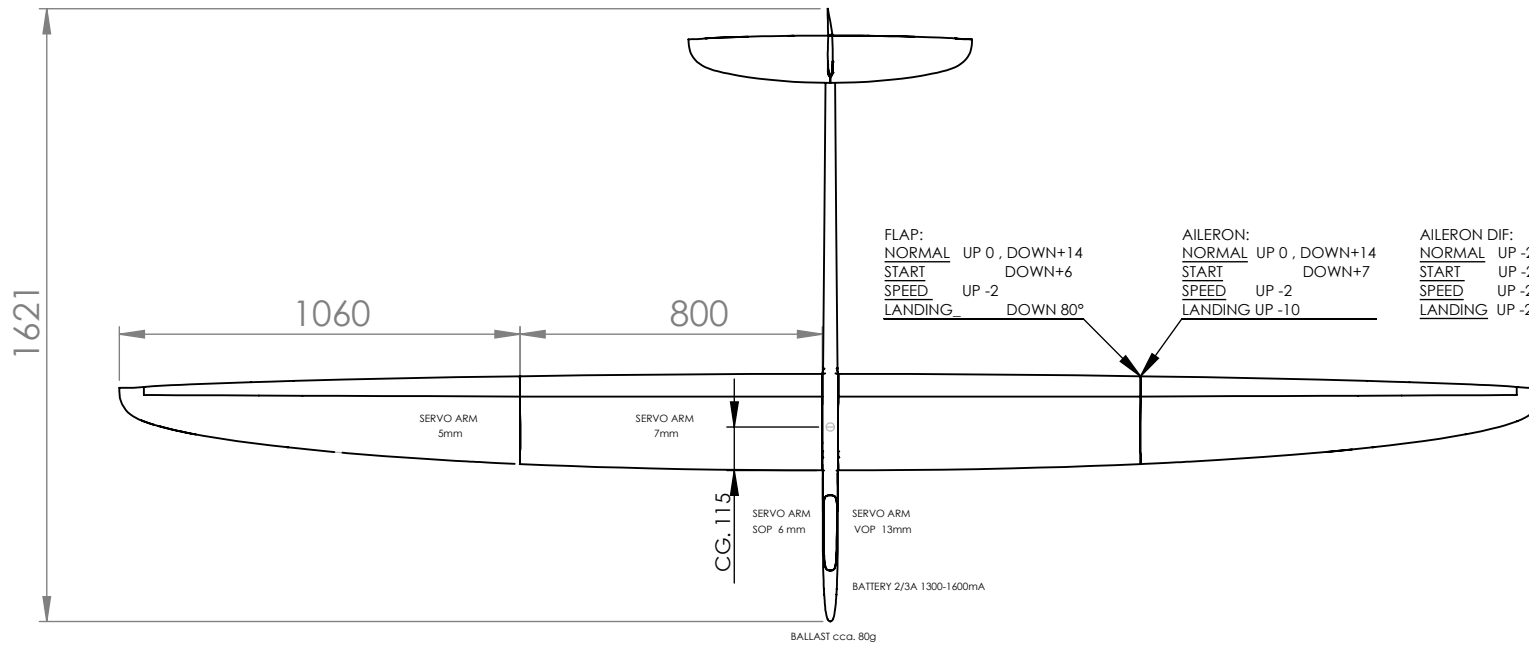

FLAP:	AILERON:	AILERON DIF:
NORMAL UP 0 , DOWN+14	NORMAL UP 0 , DOWN+14	NORMAL UP -26 , DOWN+13
START DOWN+6	START DOWN+7	START UP -26 , DOWN+13
SPEED UP -2	SPEED UP -2	SPEED UP -26 , DOWN+13
LANDING DOWN 80°	LANDING UP -10	LANDING UP -26 , DOWN+13

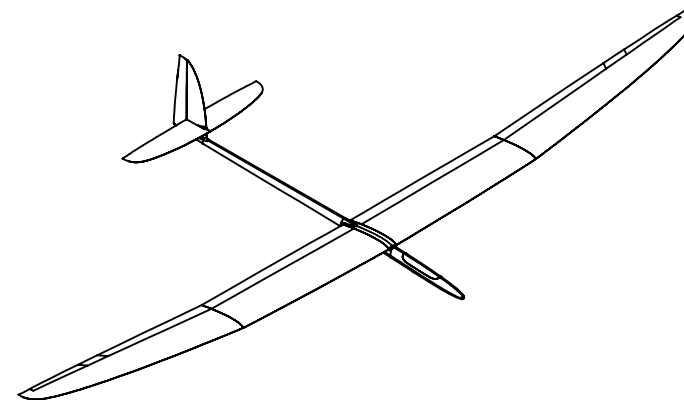
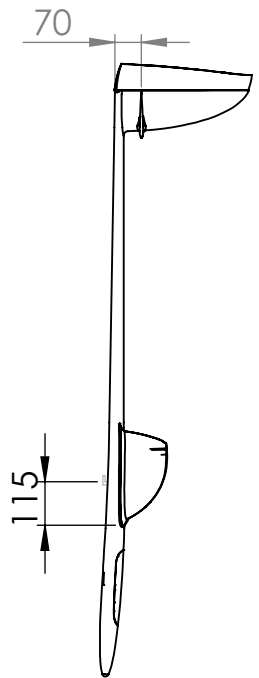

## ENJOY 3

WING AREA: 76,9 dm<sup>2</sup>

ASPEC RATIO: 18,3

WEIGHT: 1750-2100g